



Log Mate

5 1 0

Spare part manual





info@logmate.se www.logmate.se

Contents

Control system Log Mate 510	9
PWR/ETH Cable, L= 5m.....	11
USB Cable, L = 5m	13
Log Mate 510 main computer	15
Log Mate 510 Distribution Module (LDM)	17
Log Mate 500 Head Module (LHM)	19
Safety box.....	21
Operator presence cable, L = 5m	23
Miscellaneous	25
Sensor cable, 5-pole, L = 3m.....	27
Crane cable	29
Crane tip cable.....	31
Connection schematics.....	35

Spare parts

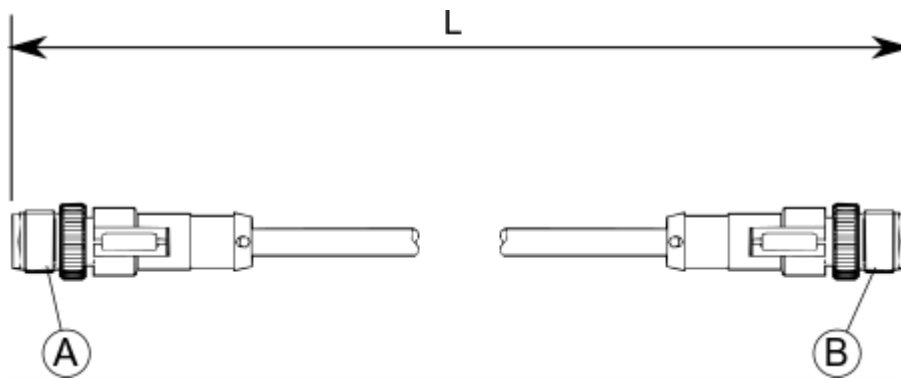

PWR/ETH Cable, L= 5m

Structure 402318				
Pos.	Part no.	Quantity	Description	Specification
A		1	Connector	8 Pole M12
B		1	Connector	8 Pole M12

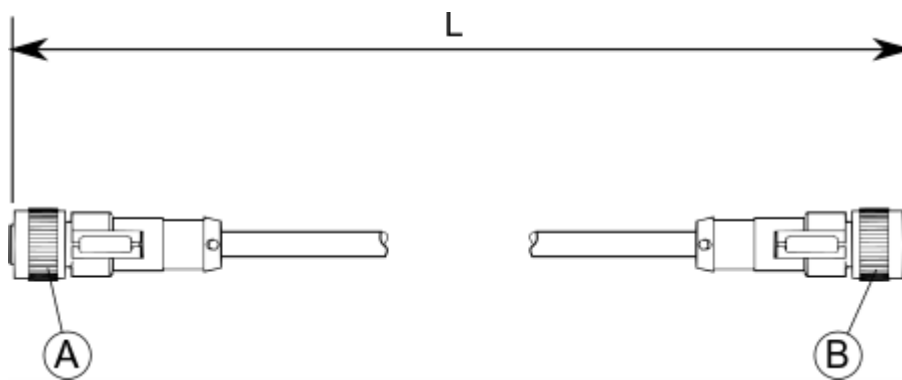

USB Cable, L = 5m

Structure 402317				
Pos.	Part no.	Quantity	Description	Specification
A		1	Connector	M12 USB Mini
B		1	Connector	M12 USB Mini

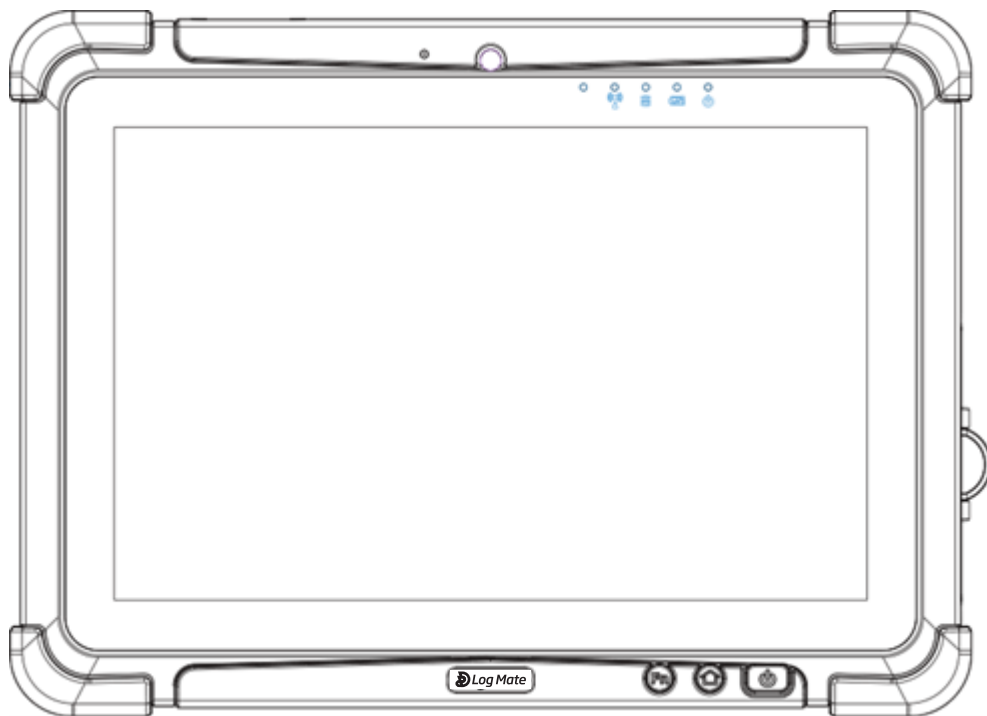

Log Mate 510 main computer

Structure 402650				
Pos.	Part no.	Quantity	Description	Specification
	402650	1	Log Mate 510	



Log Mate 510 Distribution Module (LDM)

Structure 402660				
Pos.	Part no.	Quantity	Description	Specification
	402660	1	Module	

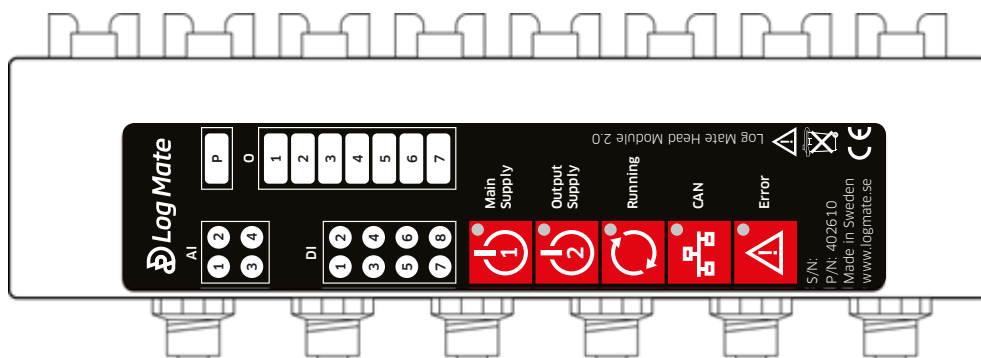

Log Mate 500 Head Module (LHM)

Structure 402610				
Pos.	Part no.	Quantity	Description	Specification
	402610	1	Head module	

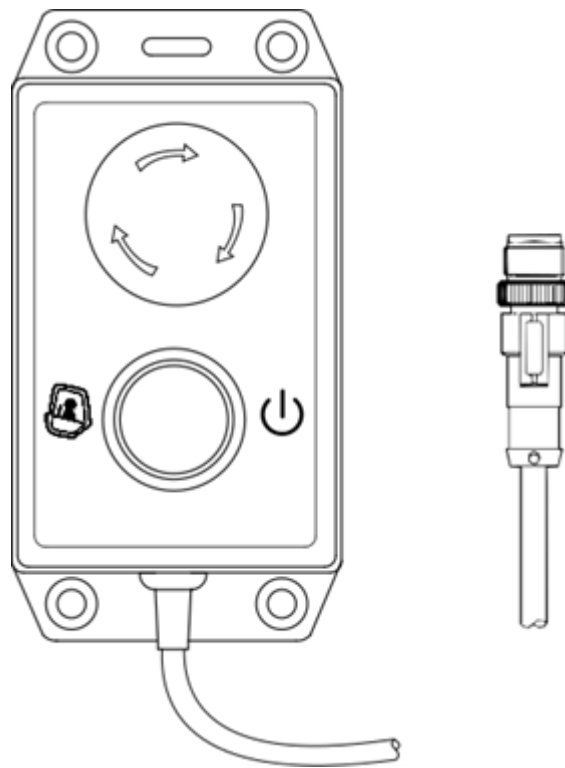

Safety box

Structure 401605				
Pos.	Part no.	Quantity	Description	Specification
	401605	1	Safety box	

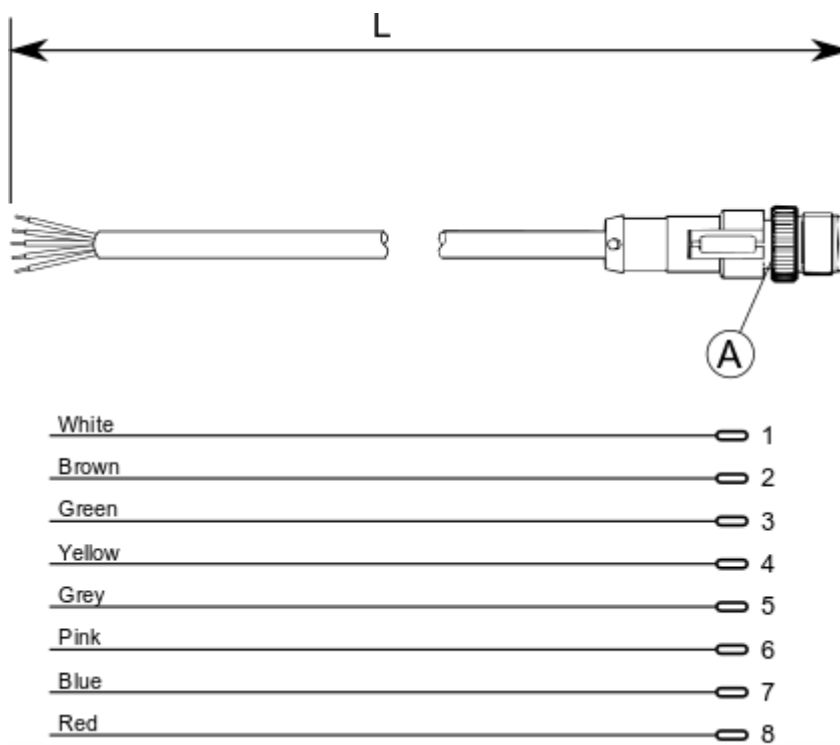

Operator presence cable, L = 5m

Structure 402572				
Pos.	Part no.	Quantity	Description	Specification
A	402572	1	Cable	8-pole

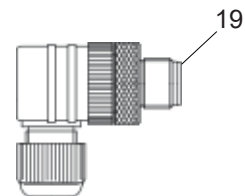
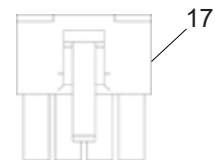
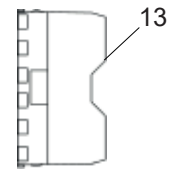
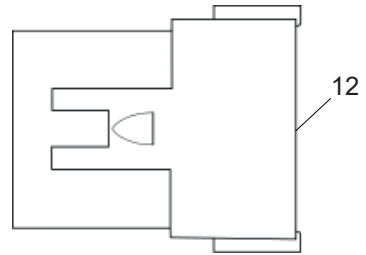
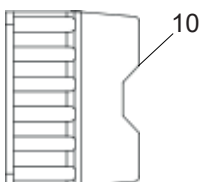
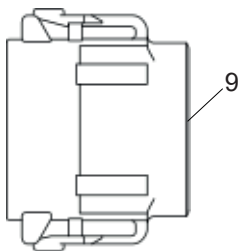
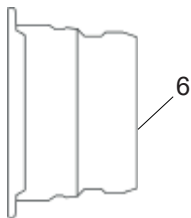
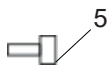
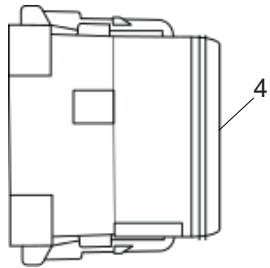
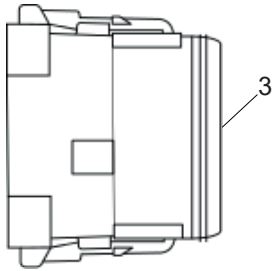

Miscellaneous

Structure				
Pos.	Part no.	Quantity	Description	Specification
1	402640		USB Hardware lock	
2	401235		Magnetic door switch	
3	402081		Connector housing	12 Pole FS type A
4	402080		Connector housing	12 Pole FS type B
5	402077		Plug	White
6	402086		Connector wedge	12 pole FS
7	402079		Socket	14-16 AWG
8	402042		Socket	16-18 AWG
9	402115		Connector housing	12 Pole FS DTM
10	402116		Connector wedge	12 Pole FS DTM
11	402107		Socket	DTM, 20-24 AWG
12	402055		Connector housing	12 Pole MS type A
13	402067		Connector wedge	12 Pole MS
14	402078		Pin	14-16 AWG
15	402043		Pin	16-18 AWG
16	402133		Connector housing	16 Pole Mini-fit Jr
17	402134		Connector housing	8 Pole Mini-fit Jr
18	402135		Socket	18-24 AWG Mini-fit Jr
19	401358		Connector	M12 5 Pole angled

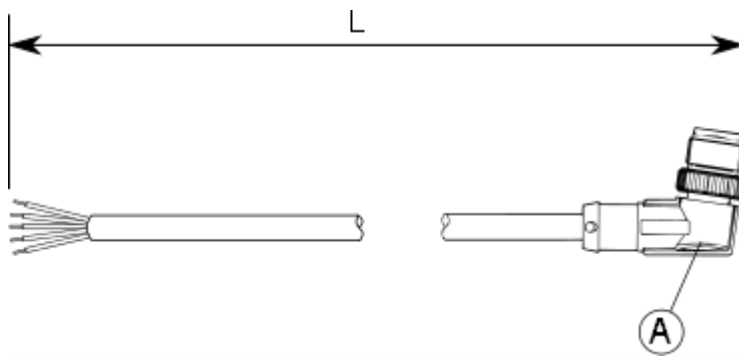

Sensor cable, 5-pole, L = 3m

Structure 402580				
Pos.	Part no.	Quantity	Description	Specification
A		1	Connector	5-pole

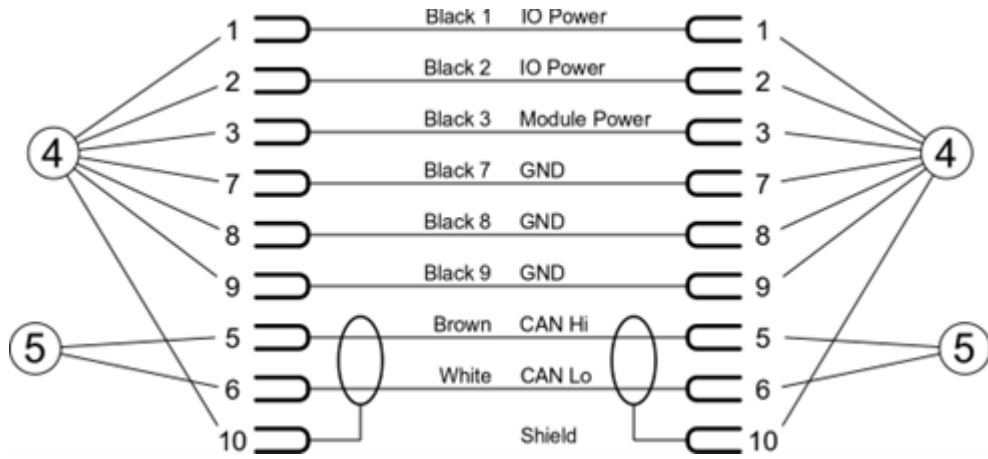
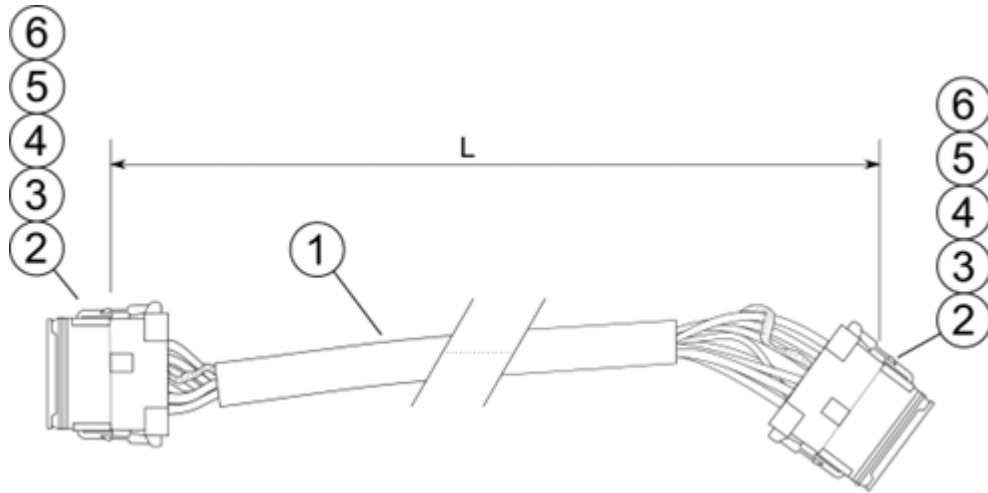

Crane cable

Structure				
Pos.	Part no.	Quantity	Description	Specification
1	401503	L	Cable	2x0,5mm + 2x3x1,5mm
2	402081	2	Connector housing	12 pole FS type A
3	402086	2	Connector wedge	12 pole FS
4	402079	14	Socket	14-16 AWG
5	402042	4	Socket	16-18 AWG
6	402077	6	Plug	White

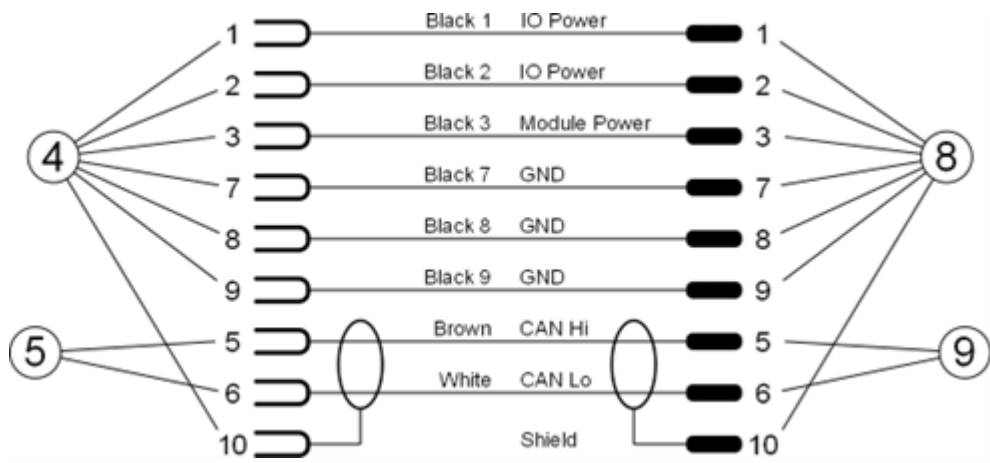
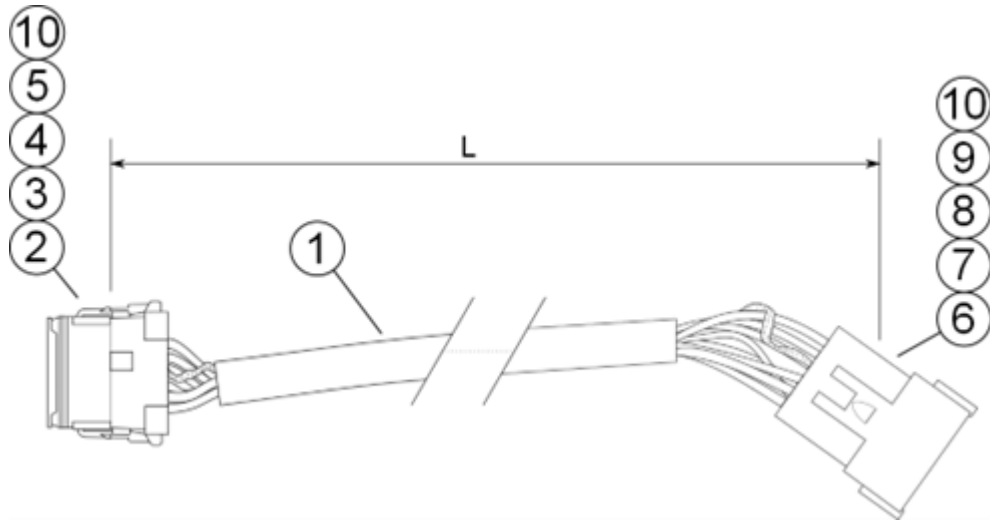

Crane tip cable

Structure				
Pos.	Part no.	Quantity	Description	Specification
1	401503	L	Cable	2x0,5mm + 2x3x1,5mm
2	402081	1	Connector housing	12 pole FS type A
3	402086	1	Connector wedge	12 pole FS
4	402079	7	Socket	14-16 AWG
5	402042	2	Socket	16-18 AWG
6	402055	1	Connector housing	12 pole MS type A
7	402067	1	Connector wedge	12 pole MS
8	402078	7	Pin	14-16 AWG
9	402043	2	Pin	16-18 AWG
10	402077	6	Plug	White

Structure				
Pos.	Part no.	Quantity	Description	Specification
	401611		Bracket	Log Mate 510
	402836		Data caliper	500mm
	402837		Data caliper	600mm
	402838		Data caliper	800mm
	402842		Harvester kit	Haglöfs caliper
	402635		GPS-receiver	
	045526		Electrical repair kit	

Connection schematics

Kopplingschema

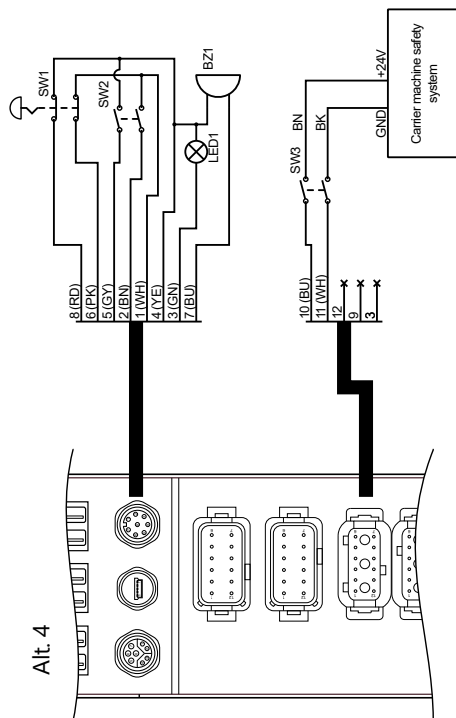
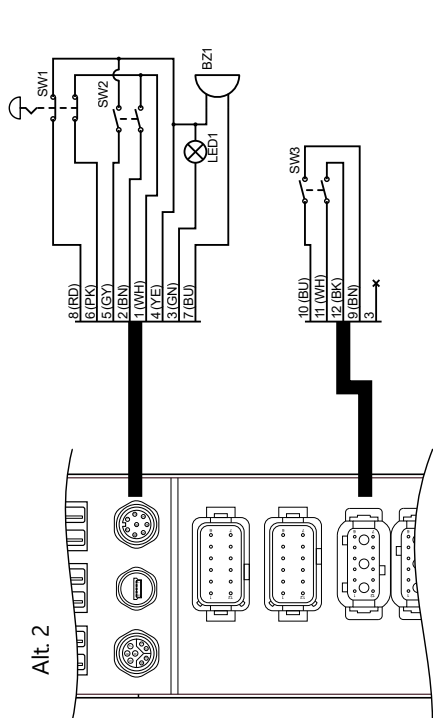

Log Mate 510
Operator presence
safety system wiring

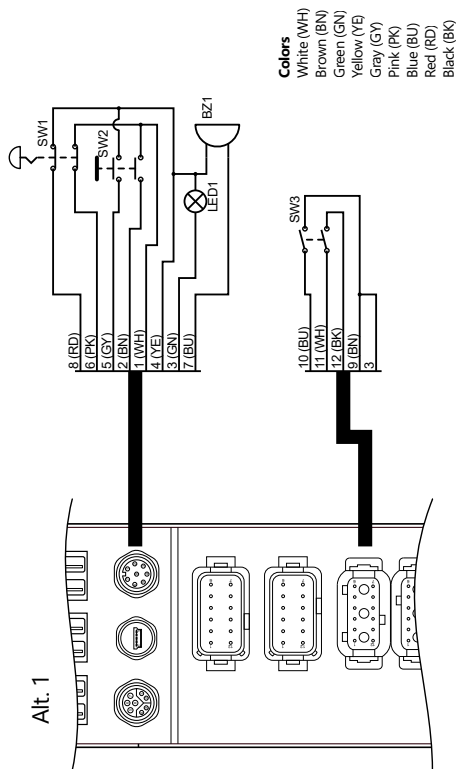

- Colors**
- White (WH)
 - Brown (BN)
 - Green (GN)
 - Yellow (YE)
 - Gray (GY)
 - Pink (PK)
 - Blue (BU)
 - Red (RD)
 - Black (BK)

